

Miba Industrial Bearings ZR Pedestal Bearing

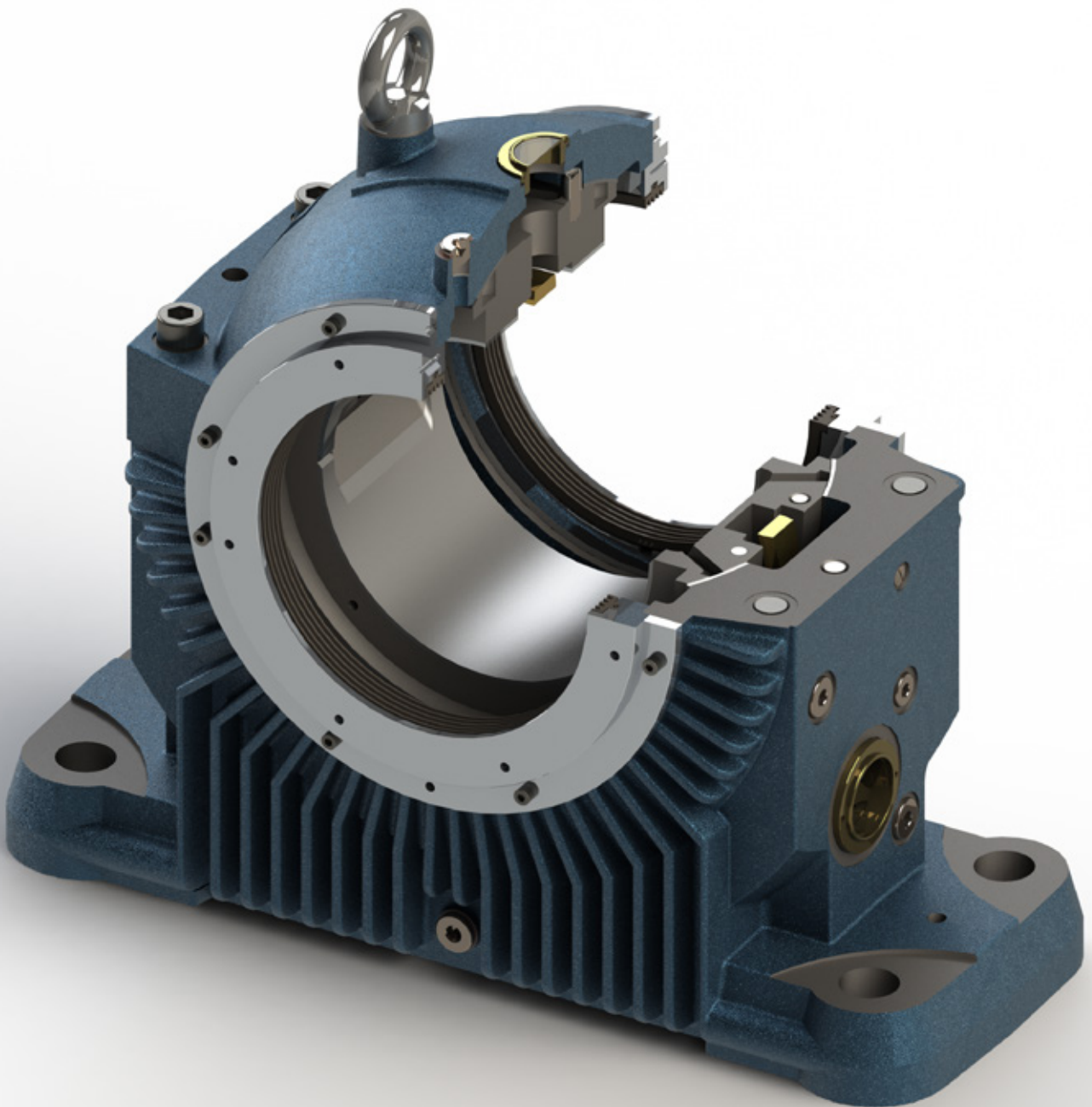



Miba Industrial Bearings

The Industrial Bearing Branch of the Miba Bearing Group produces hydrodynamic bearings and labyrinth seals for use in mechanical and plant engineering which are used in a wide range of high-performance applications.

Our highly inspired teams, work diligently to serve our customers the best bearing solutions for each and every application.

Content

Side

Description of the ZR design	3
Radial bore profile selection	6
Oil flow	6
Radial and axial loads	7
ZR bearing dimensions	8
Dimensions of shaft	10
Types and dimensions of seals	12
Bearing types and designations	14
Checklist	15

Description of the ZR design

The type Miba ZR horizontal bearing is designed according to DIN 31690 norm specifications for a wide range of heavy duty applications (electrical machines, turbines, blowers and test rigs). The modular system applies to the different types of bearings (pedestal, end flange and center flange), i.e. it is always possible to combine different modules of this system such as shell, lubricating ring and other equipment. Thus, assembly is simple and mistakes due to the positioning of screws and pins are avoided during installation, commissioning and maintenance procedures.

Housing

The bearing housings are finned and manufactured from nodular cast iron EN-GJS-400-15 (formerly GGG 40) giving high strength. Upon request, they can be supplied in gray cast iron EN-GJL-300 (formerly GG 30) or in nodular cast iron EN-GJS-400-18-LT (formerly GGG 40.3).

The spherical seat in the housing ensures easy alignment during assembly and the loads are evenly distributed into the lower part of the housing. Therefore these bearings are designed for highest stress applications. Thread holes for monitoring the temperature, for oil inlet and outlet, as well as for oil level, are provided on both sides of the housing as standard. The housing comes with an

oil sight glass on one side. The opposite side is supplied plugged and may be used as an oil outlet. If needed, their positions can be exchanged by reversing these parts.

In the top half of the housing, a sight glass, which permits the loose oil ring to be viewed, and a plugged manual oil feeder are provided. The basic design can be easily amended, if required, to incorporate water cooling tubes, oil sump heater, vibration detectors (angled at 45°), horizontal, vertical and axial vibration sensors and earthing devices. Upon request, thread holes can be provided in the ZR housing to meet all 541 and 546 requirements for API norms.

Bearing shells

The shell is supplied in halves and spherically seated in the housing, ensuring easy self-alignment during assembly. The material is low carbon steel, lined with high tin-based white metal. This construction ensures an easy assembly and a long life cycle. Bearing shells with plain cylindrical bore and loose oil ring are used in most cases, but other shapes of bore are possible. When the specific load on start-up is too high, or for very slow-speed applications, a hydrostatic jacking system can be incorporated. Bearing shells can be provided with or without thrust faces.

.....
Q-type shells have no thrust capability for non-locating bearings.

B-type shells with plain white metal lined shoulders with oil grooves are suitable for small, temporary thrust loads.

K-type shells have taper land faces for medium thrust loads and both directions of rotation.

D-type shells, with taper land faces suitable for only one direction of rotation, are capable of absorbing higher thrust loads.

A-type shells, for the highest loads, are equipped with thrust tilting pads.
.....

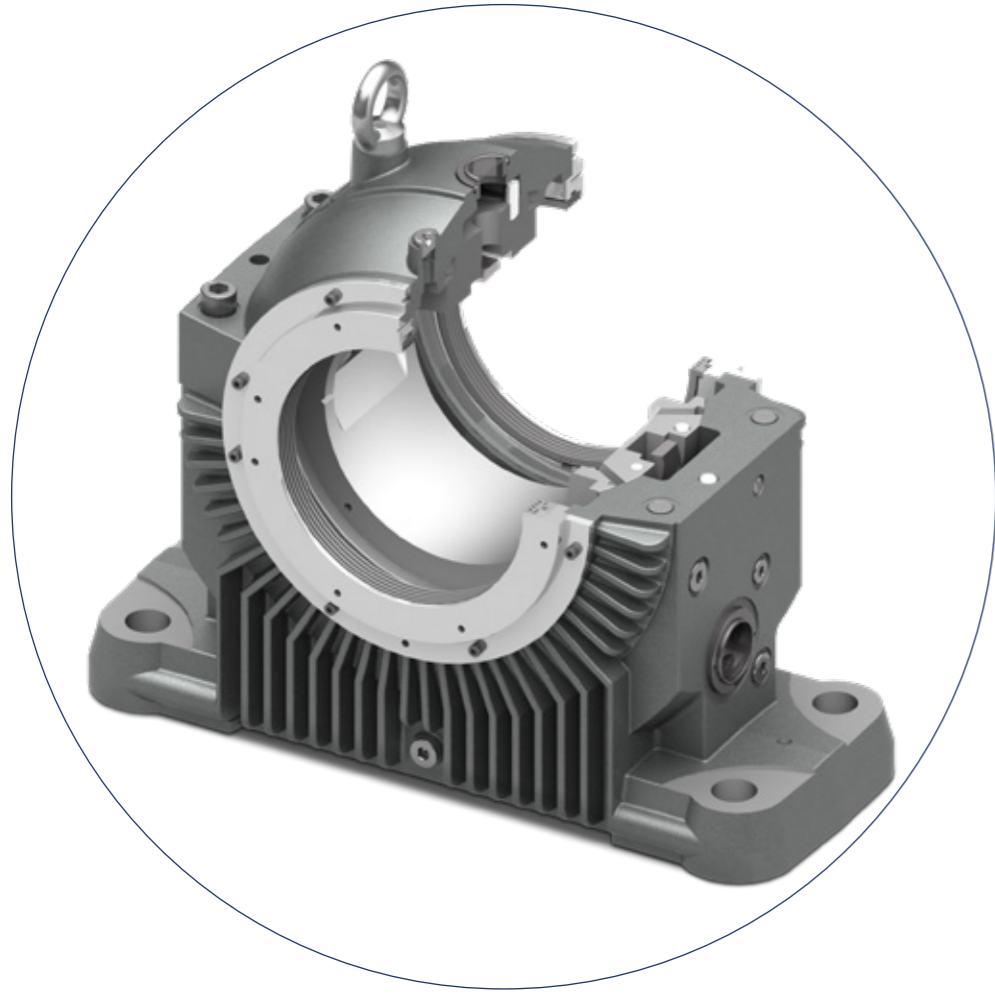

Oil supply

Fully self-contained lubrication is achieved by using a loose oil ring. Alternatively, where bearings are lubricated by an external oil circulation system, this loose oil ring can be used to permit an emergency shutdown without damage in case an oil system failure occurs. Z-bearings can be used for marine applications, where an oil ring guide assures proper lubrication even if extreme vessel motions occur.

Electrical insulation

To prevent stray currents conducted by the shaft, Z-bearings can be supplied electrically insulated as an option. In this case, the spherical seat of the housing is coated with a wear-resistant and temperature-resistant synthetic material. Upon request, a grounding wire is provided to short out this insulation, passing through a thread hole (PG 7) in the housing.

Sealing

The seals are selected for the different operation conditions and environments and for the requested protection level. The standard arrangement is the floating labyrinth seal (IP 44) made of high heat resistant, fiber-reinforced synthetic material. Bearings for high oil throughput are equipped with adjustable rigid seals (IP 44) made of aluminium alloy. Both types of seals can be equipped with bolt-on baffles (IP 55) or dust flingers (IP 54) if the bearing is operating in a dusty or a wet environment, or if rotating parts (clutches, couplings, fans etc.) are fitted close to the bearing. Special seals offering higher protection, or pressurized seals etc., can be supplied for special applications upon request. An end cover is used when the end of the shaft is inside the bearing housing.

Temperature control

Provisions for the fitting of thermo sensors in the journal bush and oil sump are provided as standard. The type of sensor to be used depends on the type required by the readout equipment used (direct reading, centralized control system, recording instrument, etc.). For bearings with high thrust loads, additional thermometers for the thrust part can be integrated.

Selection of oil

It is recommended that any branded mineral oil which is inhibited against foaming, ageing and oxidation is used as lubricant. The viscosity is suggested by Miba Industrial Bearings if the customer doesn't have preferences.

Bearing calculation

Miba Industrial Bearings uses a state of the art calculation program which can provide the following outputs:

- Minimum oil film thickness
- Maximum hydrodynamic pressure
- Maximum bearing temperature
- Oil outlet temperature
- Minimum permissible oil flow
- Frictional power loss
- Stiffness and damping coefficients
- Clearance for bearing / shaft seat



Radial bore profile selection

The radial bore profile type selection depends on several conditions. Among them we have the circumferential speed and the specific pressure. The following table should help in a preliminary selection.

1 // Type of radial bearing bore profile		
Type of bore	Circumferential speed U (m/s)	Specific load p (MPa)
C/L/F Cylindrical	0 ... 30	0 ... 4
Y Two-lobe	25 ... 75	0 ... 3
V Four-lobe	25 ... 100	0 ... 2
K Radial tilting pads	15 ... 100	0 ... 2

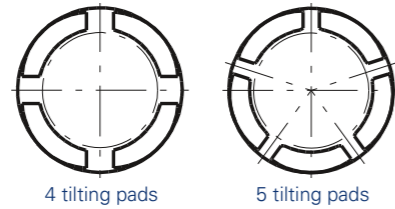
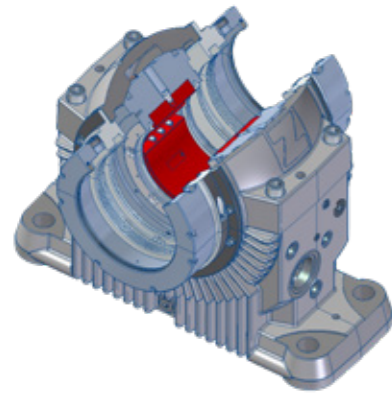

- MIBA housing bearings of all sizes 9 - 45 can be provided with tilting pad journal bearings for the highest demands
- Very high load capacity at highest circumferential speeds up to 100 m/s
- Highest stability properties

Oil flow

Z-bearings are supplied without oil inlet or outlet flanges. Upon request, as additional items, Miba Industrial Bearings can supply these flanges according to DIN 2573 or ANSI B16.5 norms. Oil outlet flanges with weir are to be mounted with the weir horizontal at the bottom. The mark on the flange will then be visible in the center of the top side.

Larger oil quantities with special outlets on request.

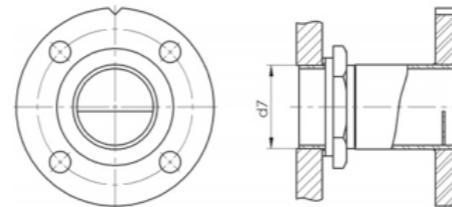

1 // Oil flow						
Size	Oil outlet thread Std	Maximum flow for oil ISO VG 32 and 46 at 40°C (l/min)	Maximum flow for oil ISO VG 68 and 100 at 40°C (l/min)	Oil outlet thread enlarged*	Maximum flow for oil ISO VG 32 and 46 at 40°C (l/min)	Maximum flow for oil ISO VG 68 and 100 at 40°C (l/min)
9	G1 ¼ (DN 32)	9	7	-	-	-
11	G1 ½ (DN 40)	11	9	-	-	-
14	G2 (DN 50)	18	16	G2 ½ (DN 65)	28	25
18	G2 (DN 50)	18	16	G2 ½ (DN 65)	28	25
22	G2 ½ (DN 65)	28	25	G3 (DN 80)	42	35
28	G2 ½ (DN 65)	28	25	G3 (DN 80)	42	35

* nonstandard enlarged oil outlet threads for bigger oil quantity applications, upon request. Additional cost will be applied.

Radial and axial loads

1 // Radial and axial loads								
Size	Diameter (mm)	F _{Radial} (N) - Type			F _{Axial} (N) - Type			
		L, C, F	Y	V/K	B	K	D	A
9	80	19.648	14.736	9.824	860	3.430	4.940	9.680
	90	22.104	16.578	11.052	950	3.840	5.600	11.060
	100	26.000	19.500	13.000	1.050	4.110	6.250	6.840
11	100	32.560	24.420	16.280	1.190	4.740	7.320	11.060
	110	35.816	26.862	17.908	1.570	6.220	9.750	12.450
	125	42.500	31.875	21.250	1.460	5.730	9.190	7.520
14	125	52.700	39.525	26.350	1.940	7.650	11.760	23.860
	140	59.024	44.268	29.512	2.500	10.040	15.380	26.510
	160	68.096	51.072	34.048	2.050	7.970	12.730	16.590
	180	76.608	57.456	38.304	2.290	9.680	14.370	-
18	160	86.848	65.136	43.424	3.080	12.420	18.340	46.300
	180	97.704	73.278	48.852	3.860	15.580	23.490	51.440
	200	112.320	84.240	56.160	3.280	12.890	20.110	32.990
	225	126.360	94.770	63.180	3.650	15.570	22.750	-
22	200	134.800	101.100	67.400	4.500	17.410	27.210	79.170
	225	151.650	113.738	75.825	5.000	19.280	30.640	87.970
	250	175.700	131.775	87.850	5.500	22.280	34.170	65.470
	280	196.784	147.588	98.392	6.100	26.570	38.350	54.980
	300	210.840	158.130	105.420	4.300	18.230	26.320	-
28	250	213.200	159.900	106.600	6.500	26.770	39.280	123.710
	280	238.784	179.088	119.392	7.190	30.050	44.110	137.450
	300	262.200	196.650	131.100	7.660	31.720	47.330	105.560
	315	275.310	206.483	137.655	8.000	34.080	49.810	96.510
	335	292.790	219.593	146.395	8.470	30.860	53.030	74.820
	355	310.270	232.703	155.135	5.750	20.890	28.050	40.220

Please note: The loads presented within the table are values for a preliminary dimensioning of the bearing size. We recommend a specific bearing calculation to review the bearing dimensions selected.

Dimensions of shaft

1 // Dimensions of shaft												
Size	D ¹⁾	b20 ²⁾ (± 0,1)	b21 ³⁾	b22	b23 ⁵⁾	d30	d31 (e8) d32 ⁴⁾	d33	d50	R1 ⁶⁾	R2 ⁶⁾	R3
9	80					110	80 / 90 / 100 / 110	90	132	2,5	4	1,6
	90	80,4	90	100	50	120		100	142			
	100					130	80 / 80 / 90 / 100	110	143			
11	100					135	100 / 110 / 125 / 140	110	157	2,5	4	1,6
	110	100,4	110	120	50	150		125	162			
	125					160	100 / 100 / 110 / 125	140	168			
14	125					170	125 / 140 / 160 / 180	140	192	4	6	2,5
	140	125,4	140	150	60	190		160	207			
	160					200	125 / 125 / 140 / 160	180	217			
	180					220		200	-			
18	160					215	160 / 180 / 200 / 225	180	244	4	6	2,5
	180	160,4	180	190	60	240		200	264			
	200					250	160 / 160 / 180 / 200	225	273			
	225					275		250	-			
	200					265	200 / 225 / 250 / 280 / 300	225	308	6	6	4
22	225					290		250	328			
	250	200,4	220	240	70	315	200 / 200 / 225 / 250 / 280	280	339			
	280					345		310	348			
	300					345		330	-			
	250					325	250 / 280 / 300 / 315 / 335 / 355	280	378	6	10	6
28	280	250,4	280	300	70	355		310	408			
	300					375		330	408			
	315					390	250 / 250 / 280 / 300 / 315 / 335	345	423			
	335					410		365	414			
	355					430		385	-			

Dimensions in millimeters

¹⁾ Limit dimensions of the shaft acc. DIN 31 698, form and positional tolerance and surfaces roughness acc. to DIN 31 699.

²⁾ Standard thrust clearance is 0,5 mm. If reversible thrust loads or shock load occur, dimension b20 can be reduced by 0,2 mm. If a locating bearing (shell type B,K) is needed only for test runs, dimension b20 can be enlarged by 4 up to 6 mm.

³⁾ If the non-locating bearing must allow larger motions (due to heat expansion or to large thrust clearances caused by the unit), dimension b21 can be enlarged.

⁴⁾ The plunge cut d32 is dropped, if it is equal or smaller as the shaft diameter D.

⁵⁾ Dimension b23 is valid for a bearing with a floating labyrinth seal.

⁶⁾ Radii R1 and R2 can be replaced by a plunge cut acc. to DIN 509

For locating bearing shell

Z...B (d30; α=10°)

Z...K (d30; α=10°)

Z...D (d30; α=10°)

Z...A (d50; α=15°)

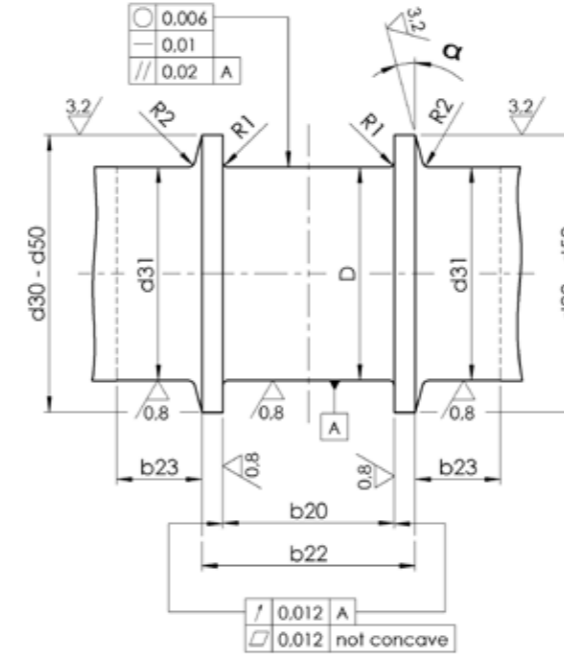

For non-locating bearing shell

Z...Q

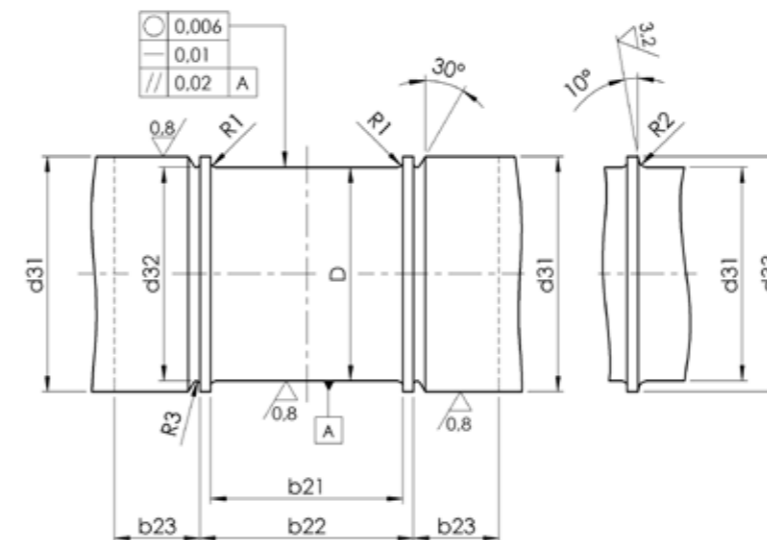

Types and dimensions of seals

1 // Types and dimensions of seals														
Size	D	b27	b28	b29	b30	b31	b32	d3	d14	d36	d37	d38	d39	d40
9	80													
	90	29	39	27	14	8	21,5	160	200	160	160	158	160	160
	100													
	110												160	160
11	100													
	110	31	41	27	16	8	21,5	190	230	190	190	188		
	125												190	190
	140													
14	125						21,5						190	190
	140	33	43	27	18	8	—	240	280	240	240	238	—	—
	160												240	240
	180						26,5							
18	160												240	240
	180	36	46	27	21	10	26,5	285	350	295	295	282		
	200												295	295
	225													
22	200						26,5						295	295
	225						—						—	—
	250	39	49	27	24	10	—	350	420	365	365	347	—	—
	280						31,5						365	365
28	300													
	250												365	365
	280										365		365	365
	300	42	52	27	27	10	31,5	450	540	480	—	447	—	—
	315													
	335										480		480	460
355														

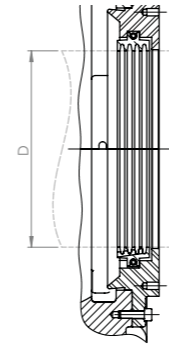

Floating labyrinth seal
(Protection IP 44)

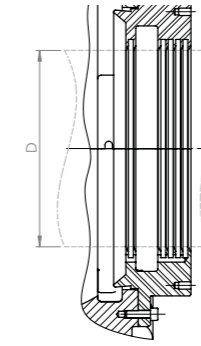

Rigid seal*
(Protection IP 44)

*Can be combined either
with a bolt-on baffle (IP 55)
or with a dust flinger (IP 54).

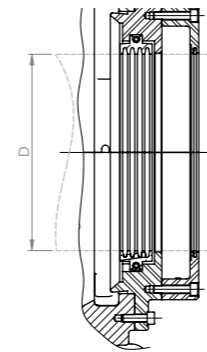

Floating labyrinth seal
with bolt-on baffle
(Protection IP 55)

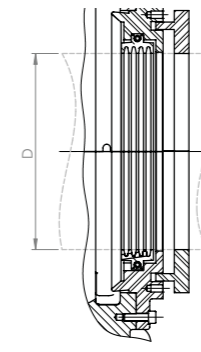

Floating labyrinth seal
with dust flinger
(Protection IP 54)

Max. axial movement of
the dust flinger $\pm 6,5\text{mm}$
(Meets NEMA spec.)

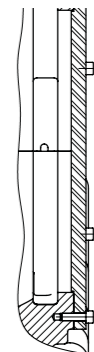

End cover

Special seal designs for specific applications upon request.

Bearing types and designations

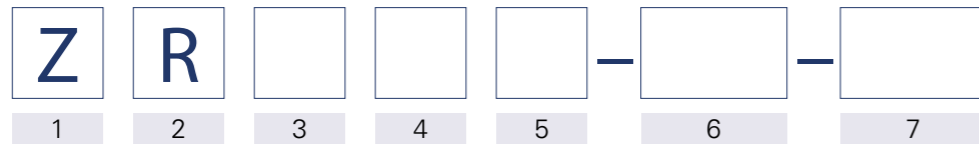

1 // Type

Z Plain bearing

2 // Housing

R Pedestal bearing, finned

3 // Heat dissipation

N Naturally cooled by convection
 Z Lubrication by oil circulation with external oil cooling
 X Lubrication by oil circulation with external oil cooling for high oil throughput
 W Finned water cooler in the oil sump
 U Recirculating oil pump and natural cooling
 T Recirculating oil pump and water cooler in the oil sump

4 // Shape of bore and type of lubrication

C Plain cylindrical bore without oil ring
 L Plain cylindrical bore with loose oil ring
 F Plain cylindrical bore with oil disk
 Y Two-lobe bore without oil ring
 V Four-lobe bore without oil ring
 K Journal tilting pads without oil ring

5 // Geometry of thrust bearing

Q Without thrust capability
 B Plain white metal lined shoulders with oil grooves
 K Tapered land thrust faces for both sense of rotation
 D Tapered land thrust faces for one sense of rotation
 A Round tilting thrust pads, cup spring supported

6 // Size

7 // Shaft diameter (mm)

Example of a bearing designation:

Z R N L B - 11 - 125

Pedestal bearing, finned, naturally cooled by convection, plain cylindrical bore with loose oil ring, plain white metal lined shoulders with oil grooves (locating or non-locating bearing), size 11, for shaft diameter 125 mm.



ZF - End flange mounted bearing

The type ZF horizontal bearing is designed acc. to DIN 31693 norm specifications for a wide range of heavy duty applications (electrical machines, turbines and test rigs)

ZM - Center flange bearing

The type ZM horizontal bearing is designed acc. to DIN 31694 norm specifications for a wide range of heavy duty applications (electrical machines, turbines and test rigs)

Disclaimer

The given statements and information herein are recommendations for the use of our products and are based on our experience in combination with applicable technical standards. They are for guidance only and do not represent any assurance of characteristics or warranty commitments for the products or their suitability for specific applications. The suitability of the products for the intended use by the user depends on different boundary conditions and influencing factors and is to be assessed exclusively by the user.

DISCLAIMER:

NO WARRANTY OR GUARANTEE, EXPRESS OR IMPLIED, IS MADE WITH RESPECT TO THE PRODUCTS, DESIGNS, DATA, INFORMATION DESCRIBED OR ANY INTELLECTUAL PROPERTY CONTAINED THEREIN. ANY WARRANTY OR GUARANTEE OF MERCHANTABILITY OR FITNESS FOR A PARTICULAR PURPOSE IS ALSO EXCLUDED. The given statements and information herein reflect the current status at the time of publication. Typing or printing errors cannot be excluded. This publication shall not be reprinted or reproduced in whole or in part in any form or by any means without the express written permission of Miba.



Checklist

- Operating conditions for calculation complete?
- Certification necessary (Lloyd's, RINA...)?
- Atex class?
- Watercooler required?
- Hydrostatic oil supply required?
- Oil inlet or outlet flanges required (flange DIN)?
- Connecting diagram filled out?
- Electrical insulation required?
- Earthing device required?
- Protection class specified?
- Sealing type and diameter (outside)?
- Sealing type and diameter (inside)?
- Sealing diameter of machine seal?
- Shaft drawing available?
- Shaft vibration sensors required (thread...)?
- Speed sensor required (thread...)?
- Absolute vibration sensor required (position, thread...)?

www.miba.com



Contacts:

Germany

Miba Industrial Bearings Germany
Osterode GmbH
Rolandsweg 16-20
37520 Osterode, Germany
MIBG_sales@miba.com

Germany

ADMOS Gleitlager GmbH
Wilhelminenhofstrasse 89a
12459 Berlin, Germany
info@admos-gleitlager.de

USA

Miba Industrial Bearings U.S. LLC
1111 Cedar Creek Rd,
Grafton, WI 53024, USA
MIBUSG_Sales@miba.com

USA

Miba Industrial Bearings U.S. LLC
3300 E 8th St.
Columbus, NE 68601, USA
MIBUSG_Sales@miba.com

USA

Miba Industrial Bearings U.S.
(Houston) LLC
1800 W 13th St, Deer Park,
TX 77536, USA
Houston.Sales@miba.com

● Miba Industrial Bearings

Brazil

Miba Industrial Bearings Brasil Ltda
Av. Manoel Inácio Peixoto, 2147
36.771-000 Cataguases, Brazil
Vendas.MIBCAT@MIBA.COM